

# Stepper Motors and Back EMF

Pete Millett

Staff Technical Marketing Engineer

June 2022



# Pete Millett – Staff Technical Marketing Engineer



## 2014–Present

- MPS Staff Technical Marketing Engineer for motor driver ICs
- Responsible for new product definitions as well as application engineering

## 2005–2013

- Systems Engineer and Systems Manager at Texas Instruments
- Product definition and systems engineering for motor driver ICs (DRV8XXX)

## 1982–2005

- Board-level hardware design engineer at various computer and consumer electronics companies

---

What is back EMF?

---

Back EMF in a stepper motor

---

Using back EMF for diagnostics

---

Summary / Q&A

# What is Back EMF?

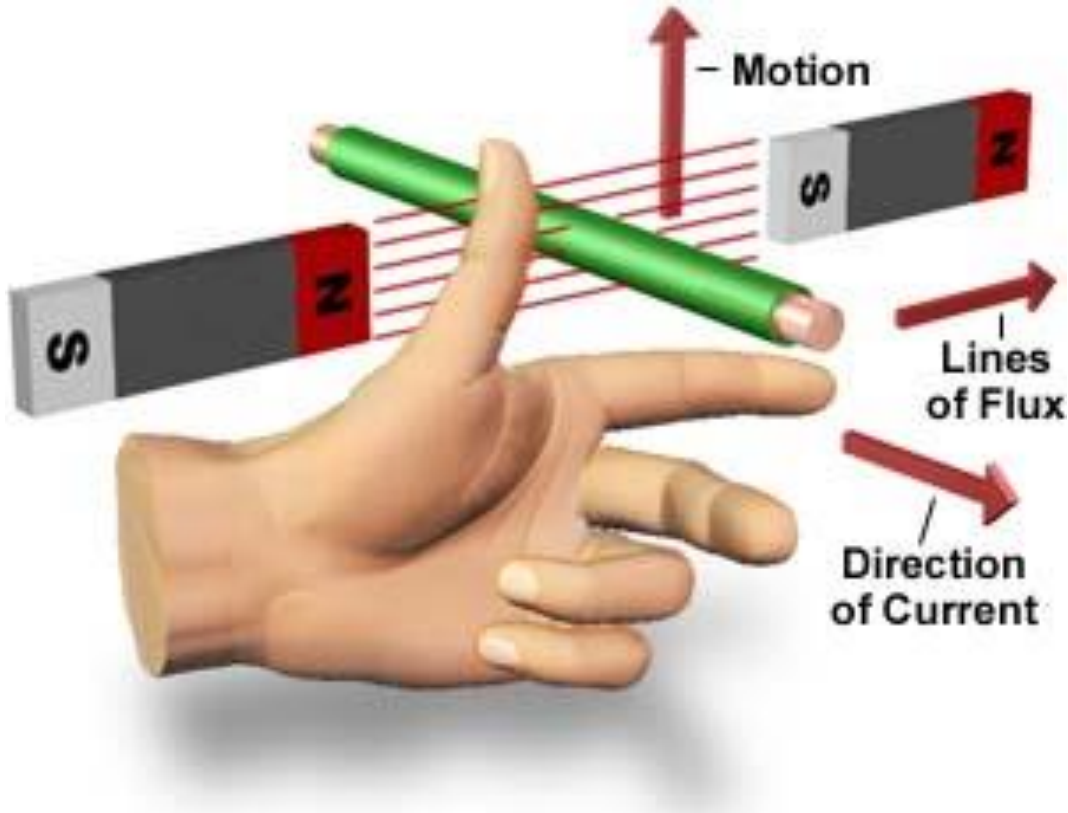
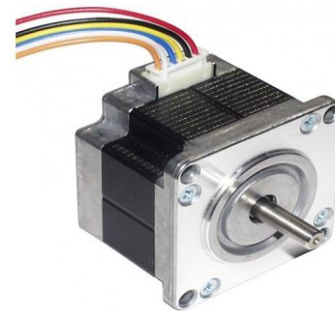

Image by Florida State University, [micro.magnet.fsu.edu](http://micro.magnet.fsu.edu)



**Brushed DC Motor**

**Brushless DC Motor**



**Stepper Motor**

# Stepper Motor Construction

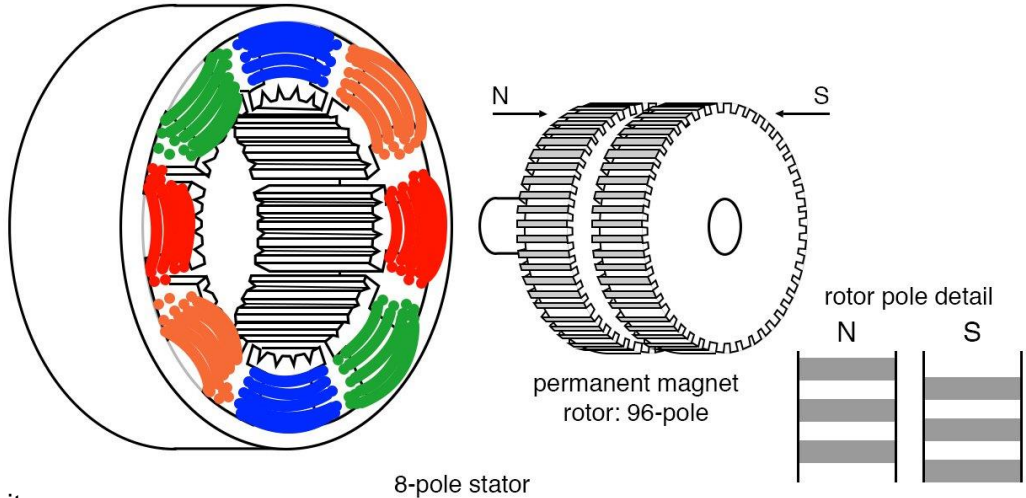
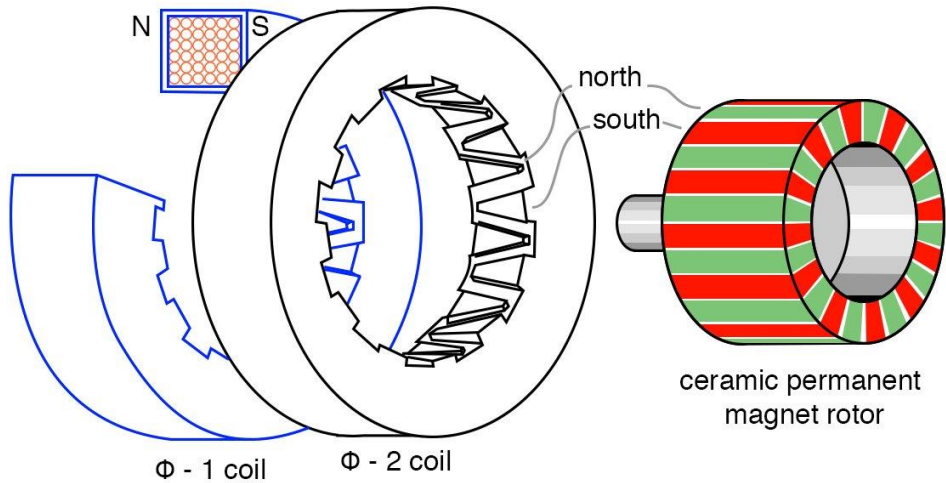
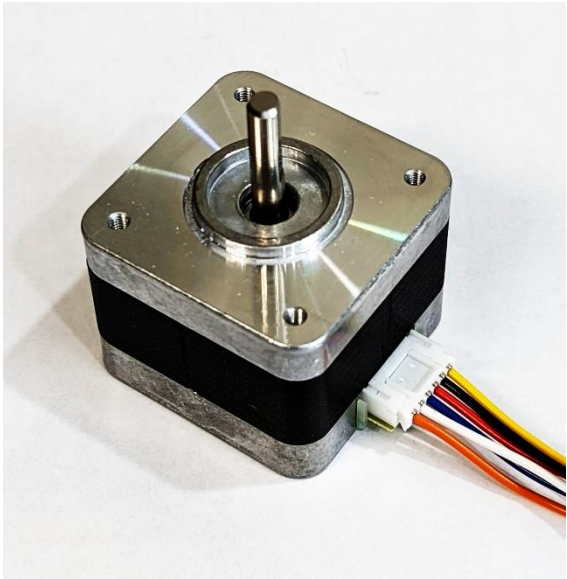
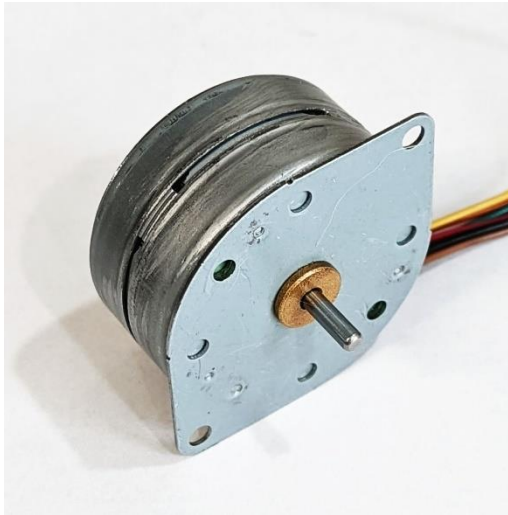

Images from [www.allaboutcircuits.com](http://www.allaboutcircuits.com)

**Permanent Magnet Stepper Motor**

**Hybrid Stepper Motor**



# Back EMF in the Stepper Motor

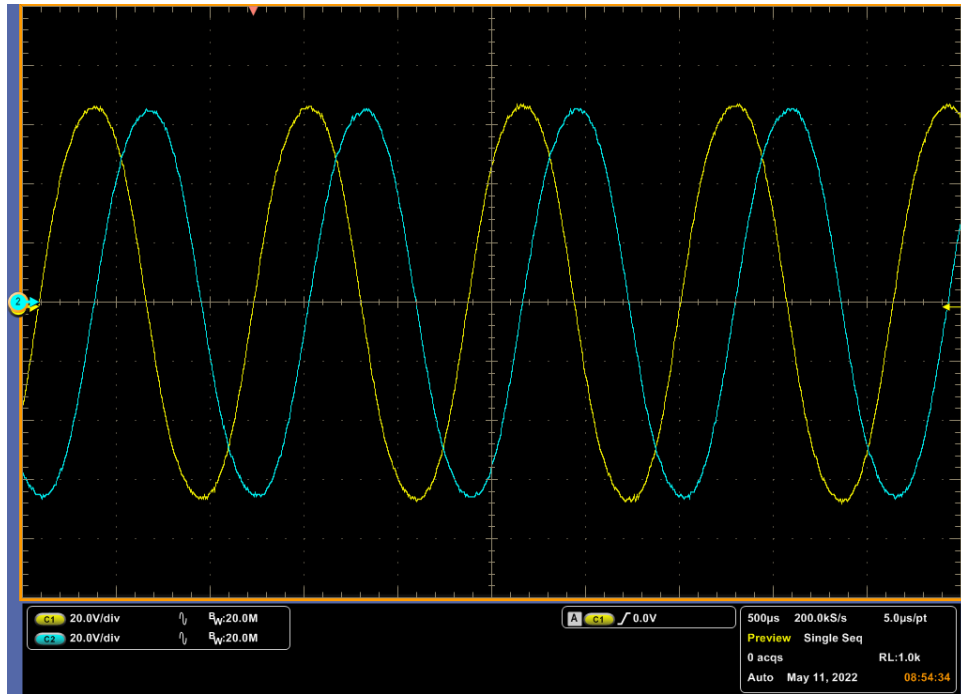



# Driving a Stepper Motor

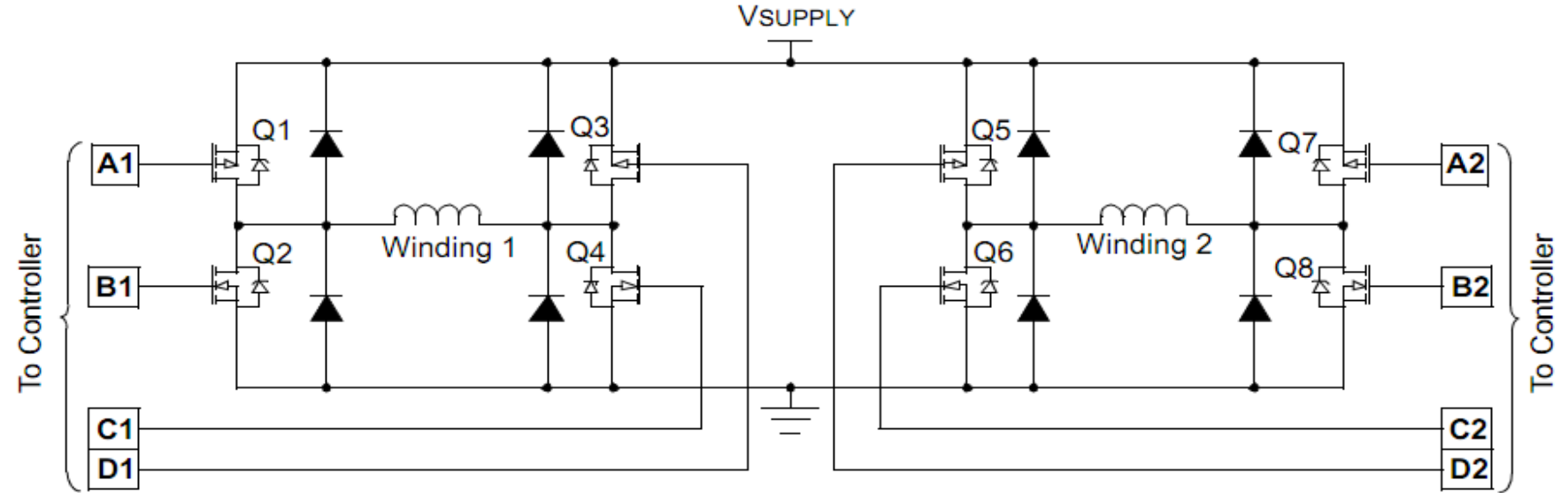
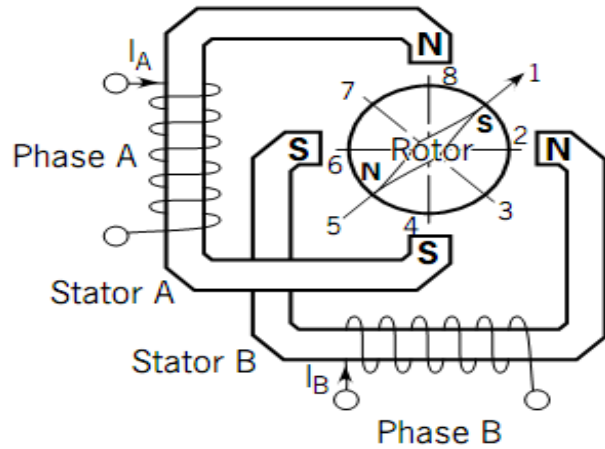

Winding current can be modulated so it approaches sine and cosine waveforms.

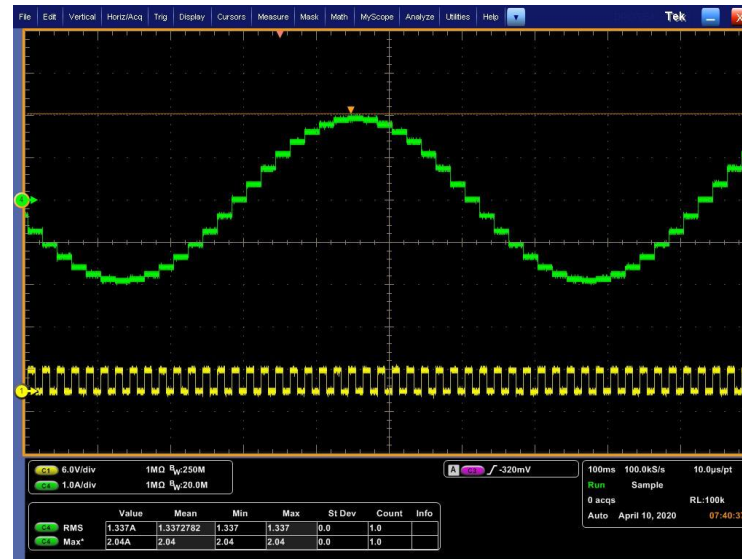

# Effect of BEMF on Winding Current

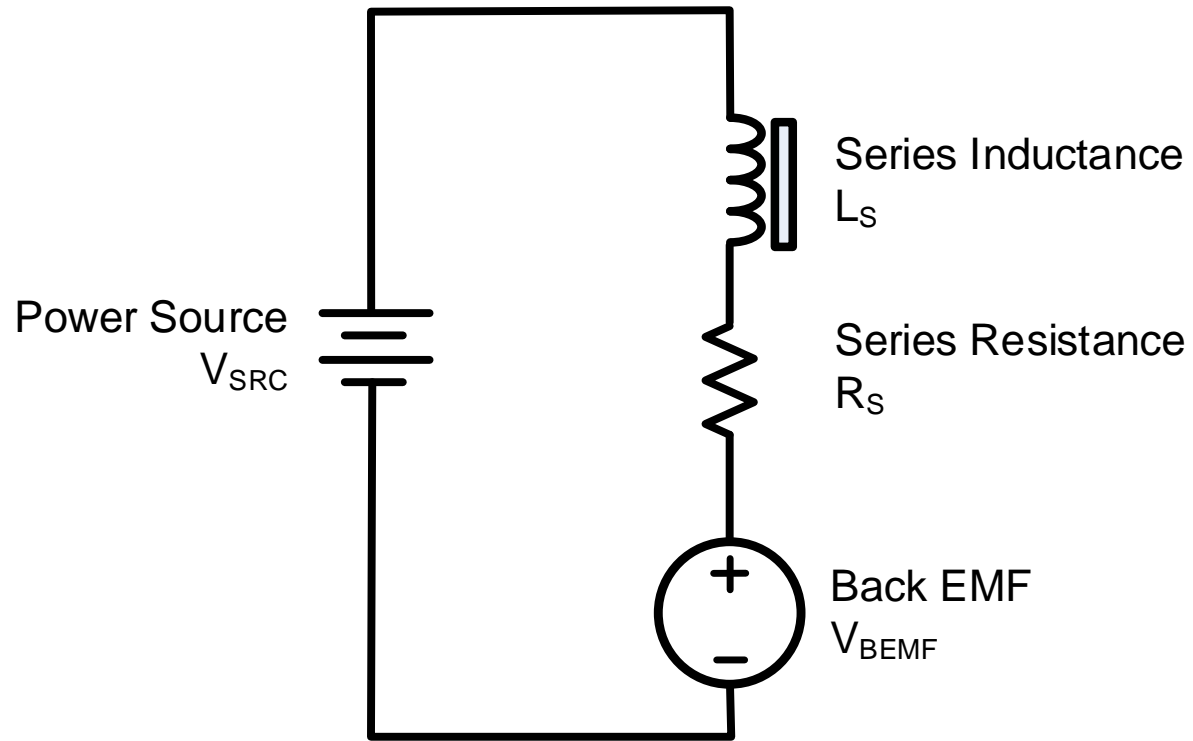

$$V = L \cdot di/dt$$



# Effect of BEMF on Winding Current

## Low Voltage

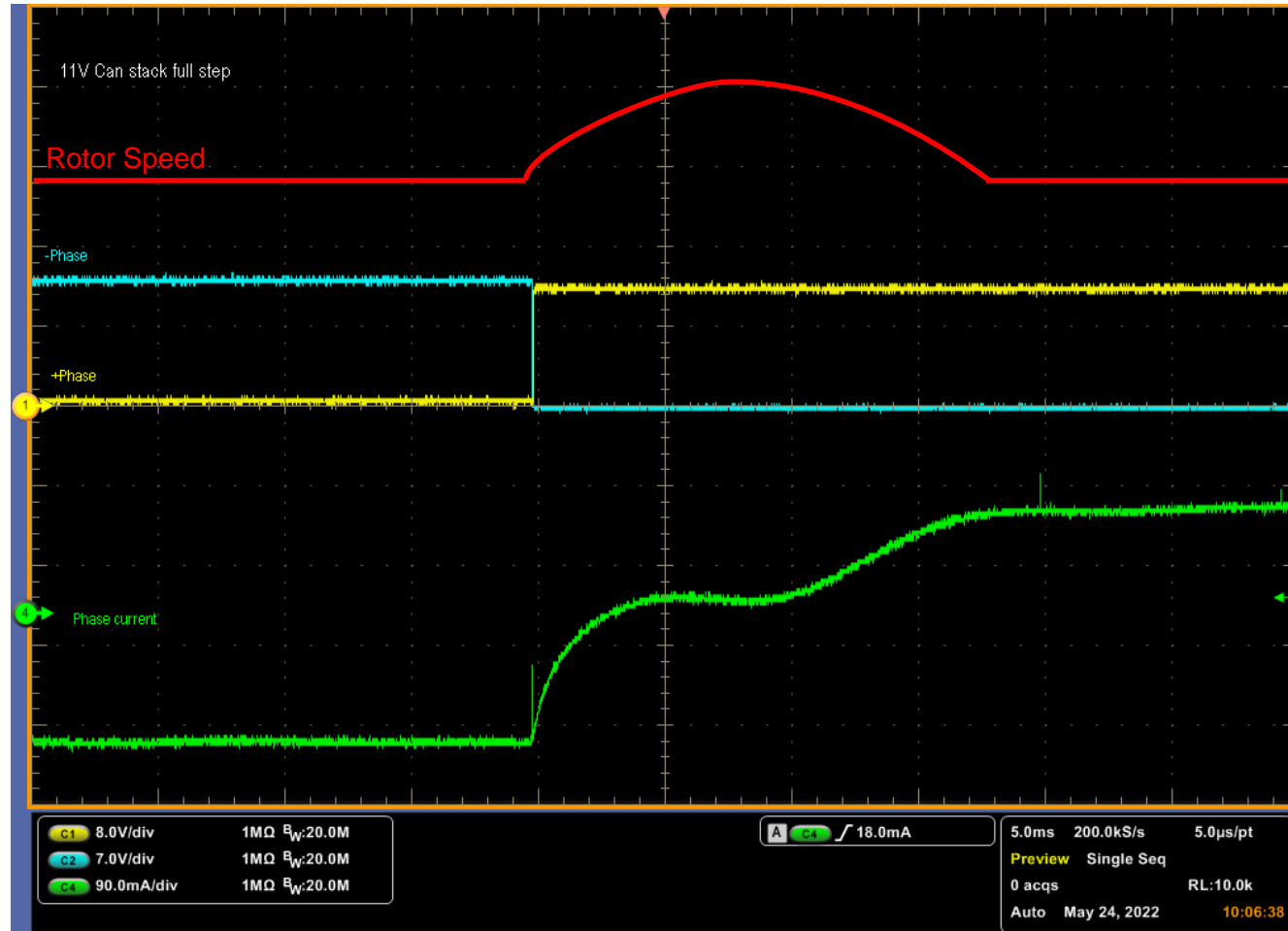

Yellow: Voltage Green: Current

# Effect of BEMF on Winding Current

## High Step Rate

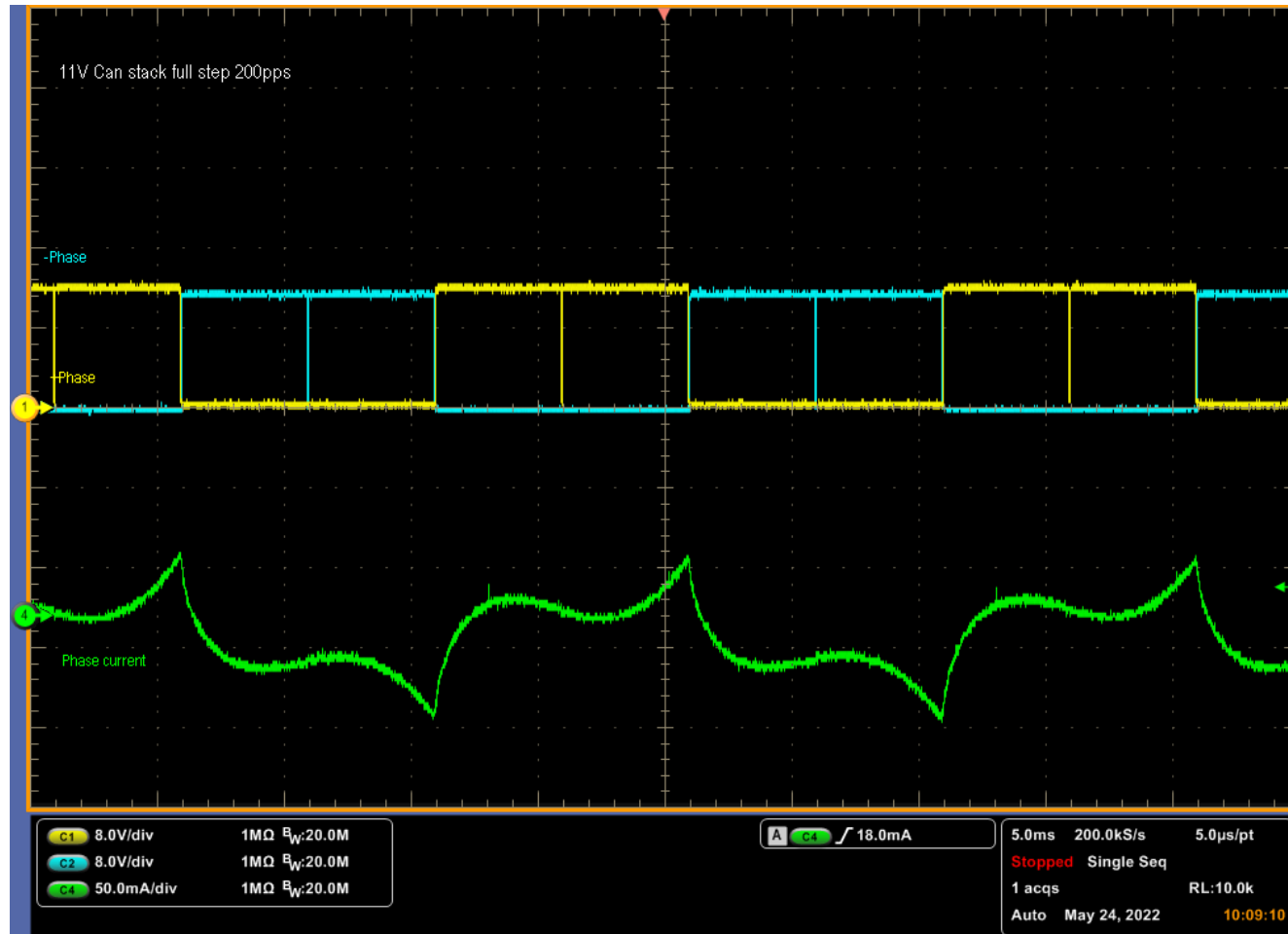

Yellow: Voltage Green: Current

# Effect of BEMF on Winding Current

## Rotor Stalled

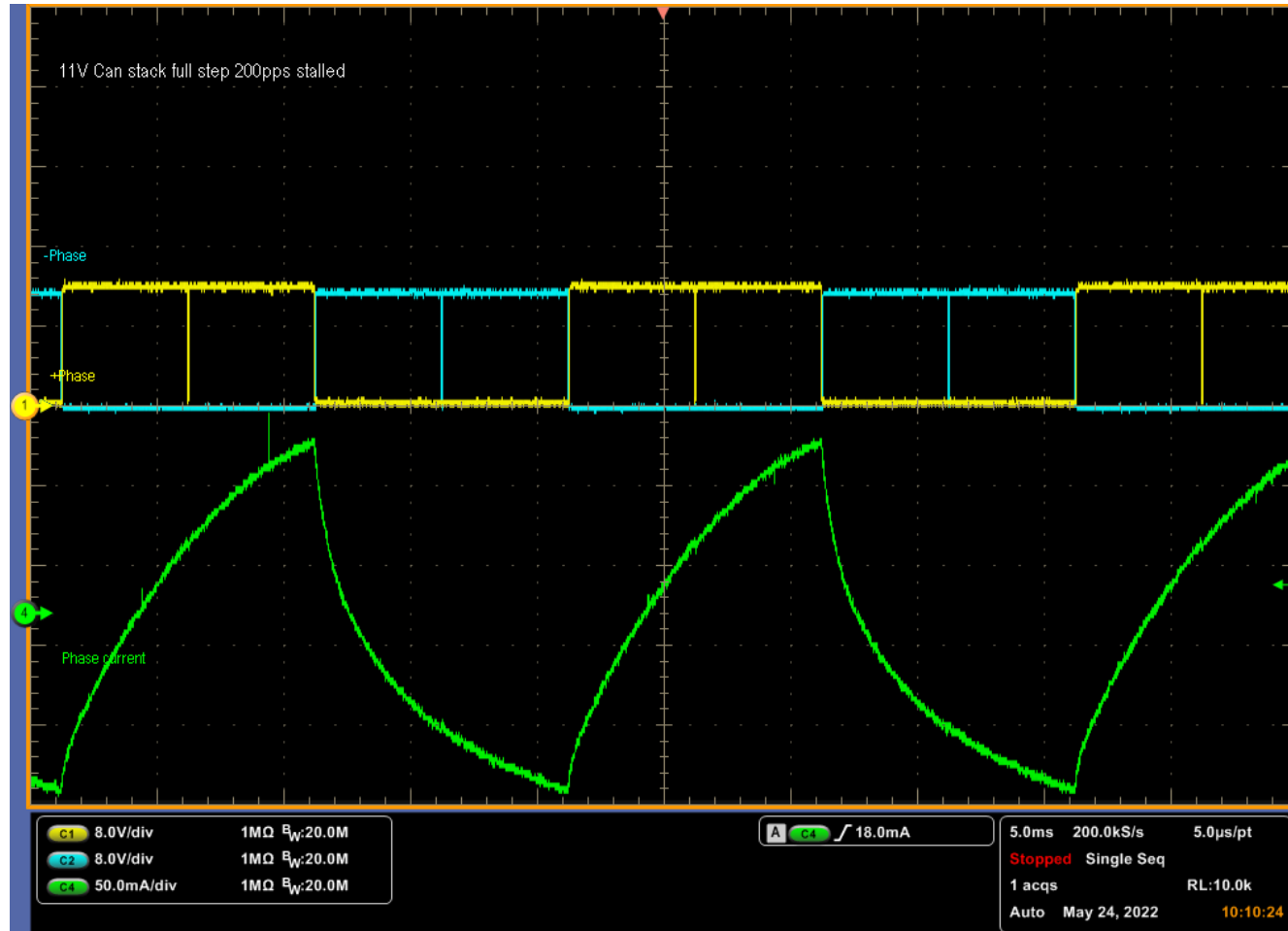

Yellow: Voltage Green: Current

# Constant Current Drive

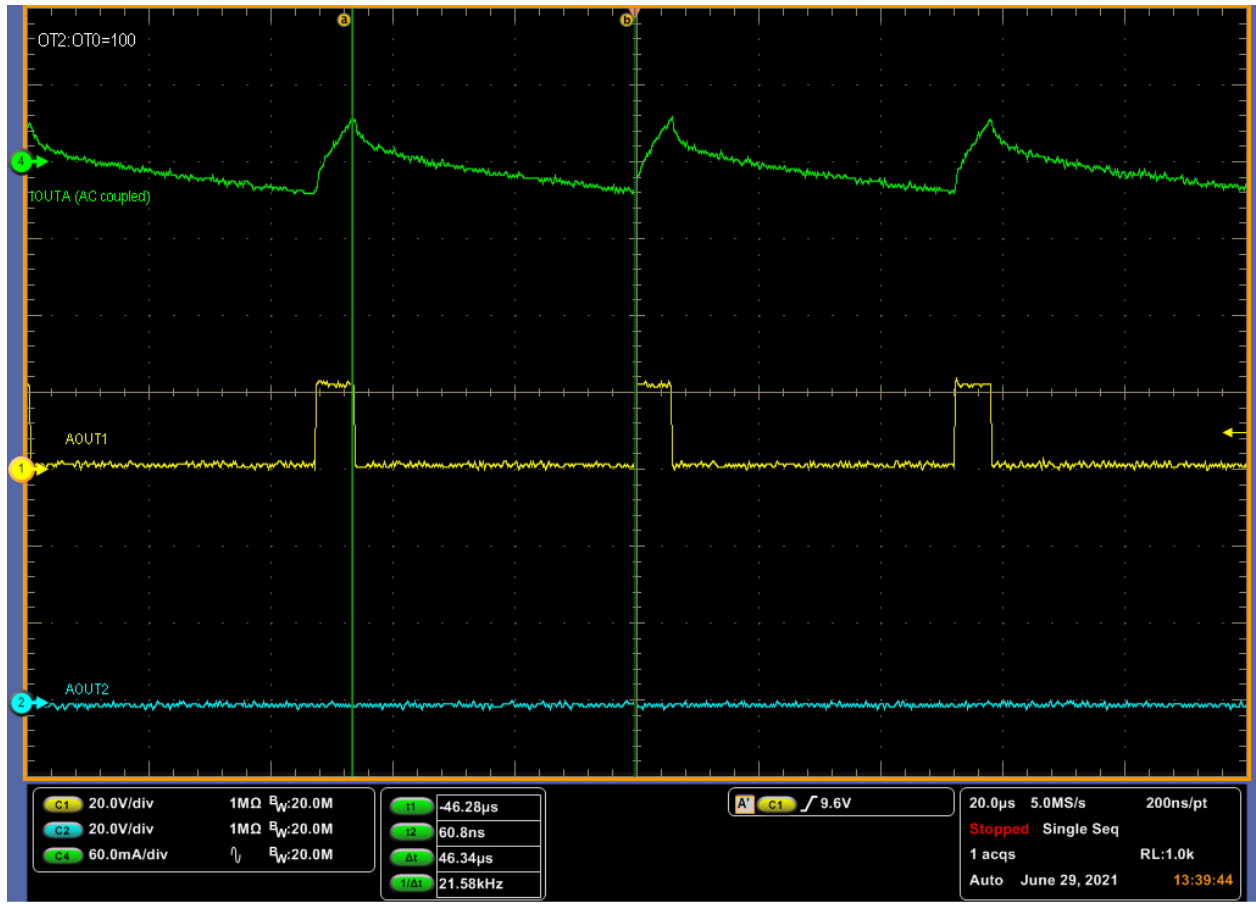

Yellow: Voltage Green: Current

# Effect of Supply Voltage on Constant Current

## High Voltage

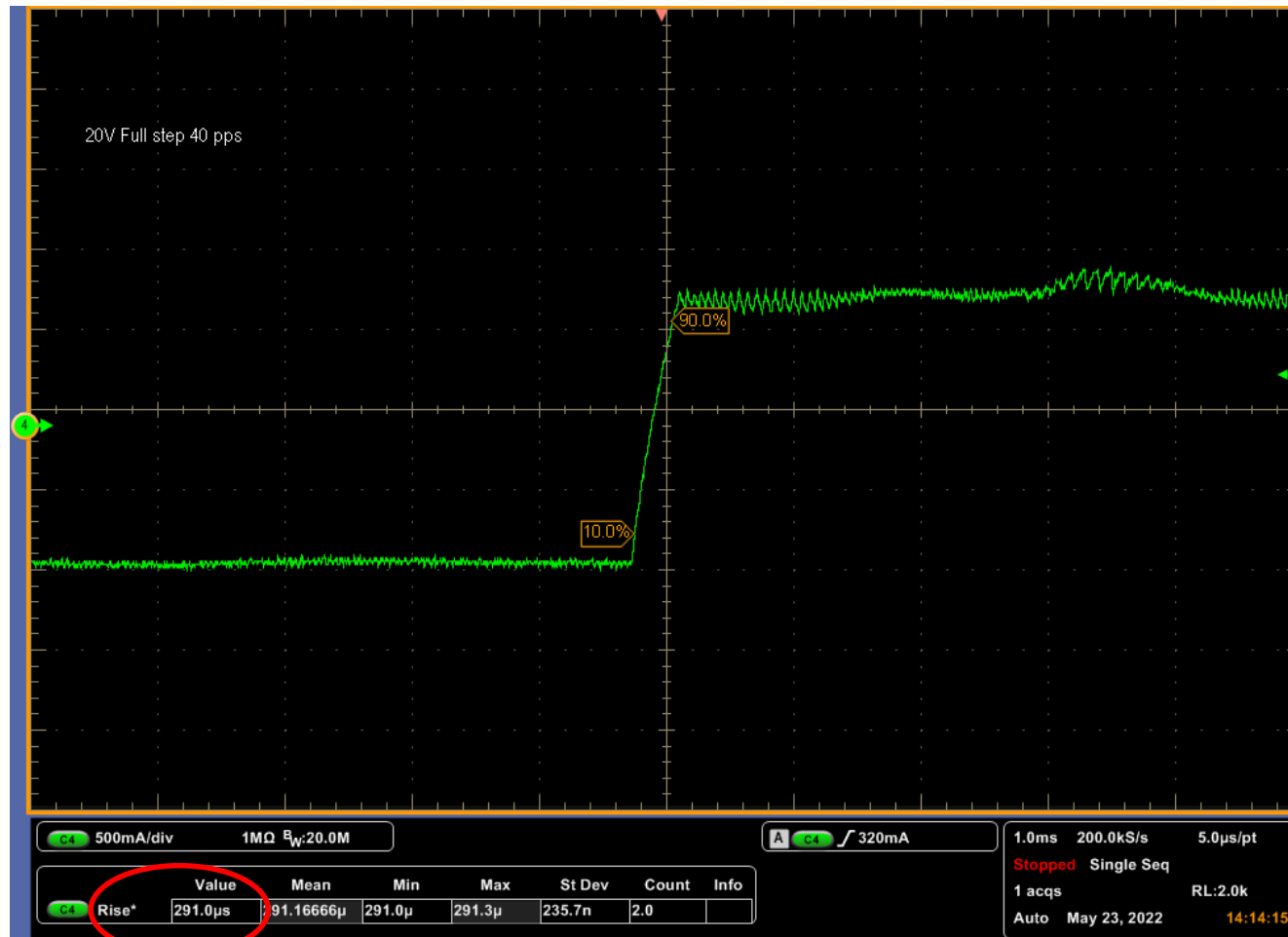

# Effect of Supply Voltage on Constant Current

## Low Voltage



# Constant Current & BEMF

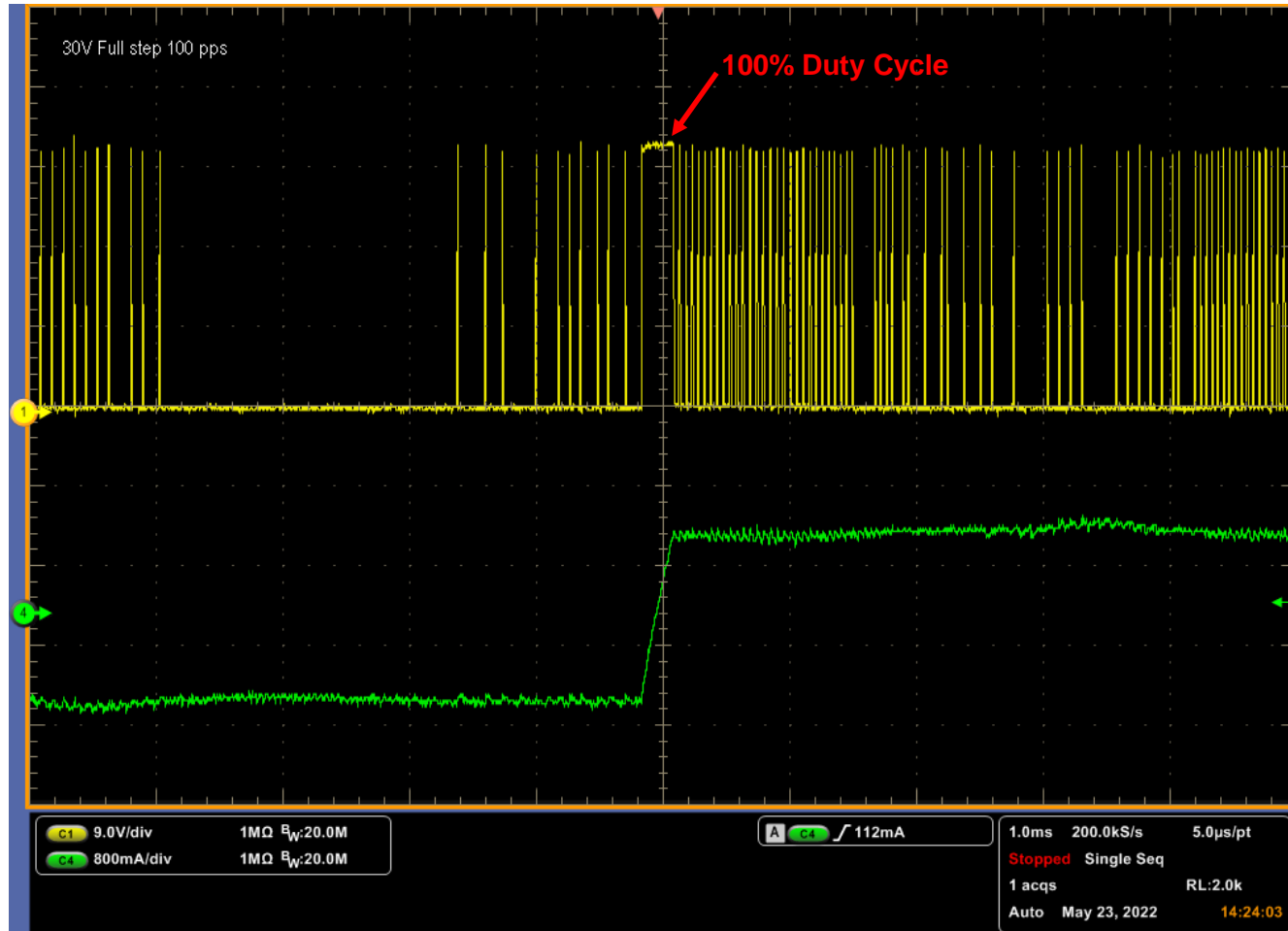

Yellow: Voltage Green: Current



# Constant Current & BEMF

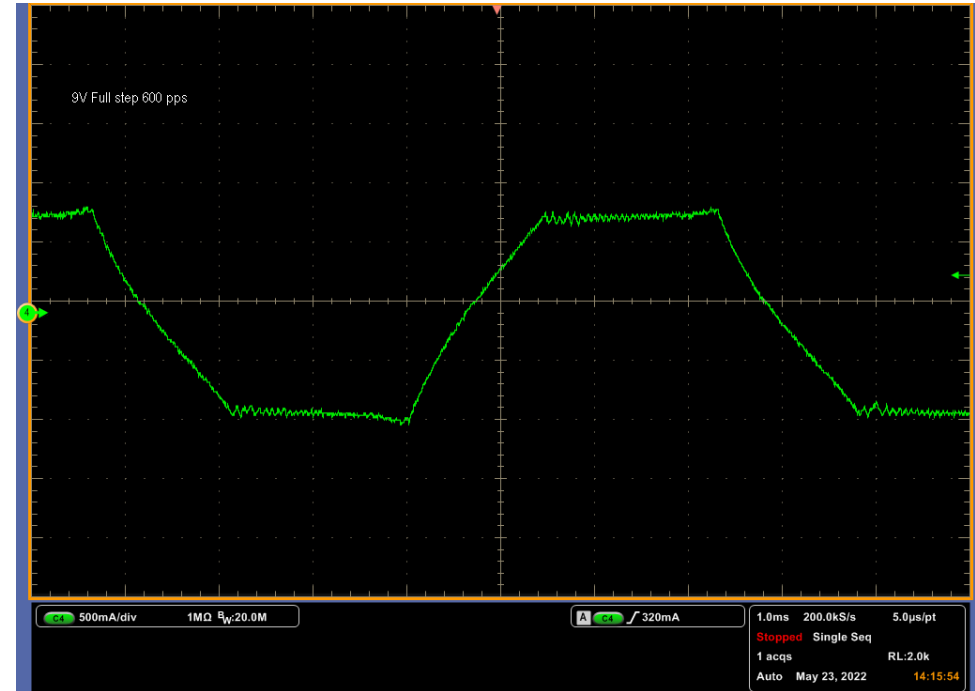
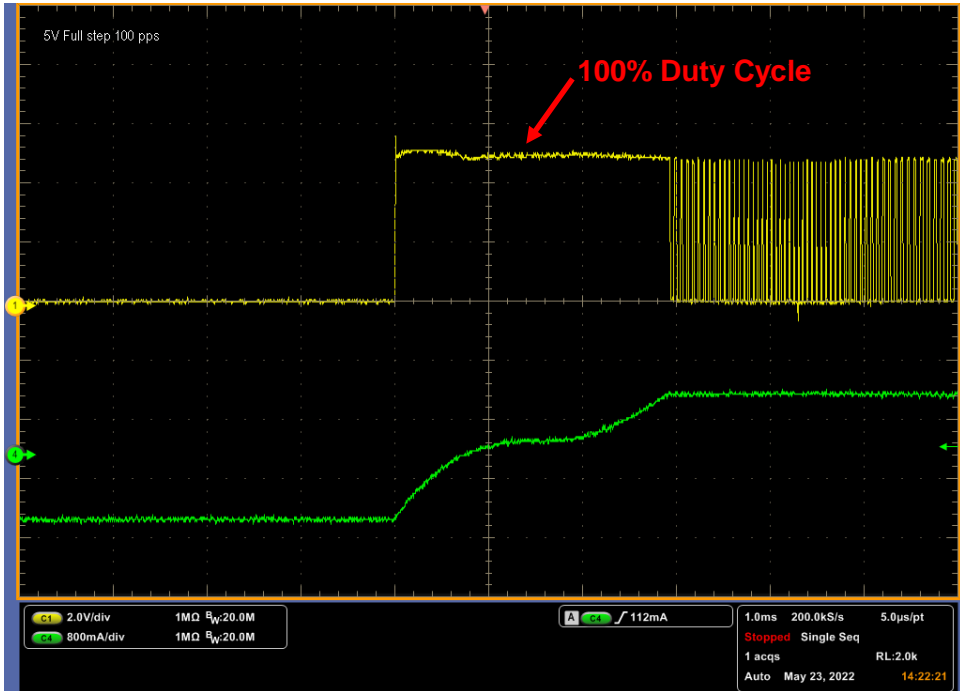

Yellow: Voltage Green: Current

# Using Back EMF Information

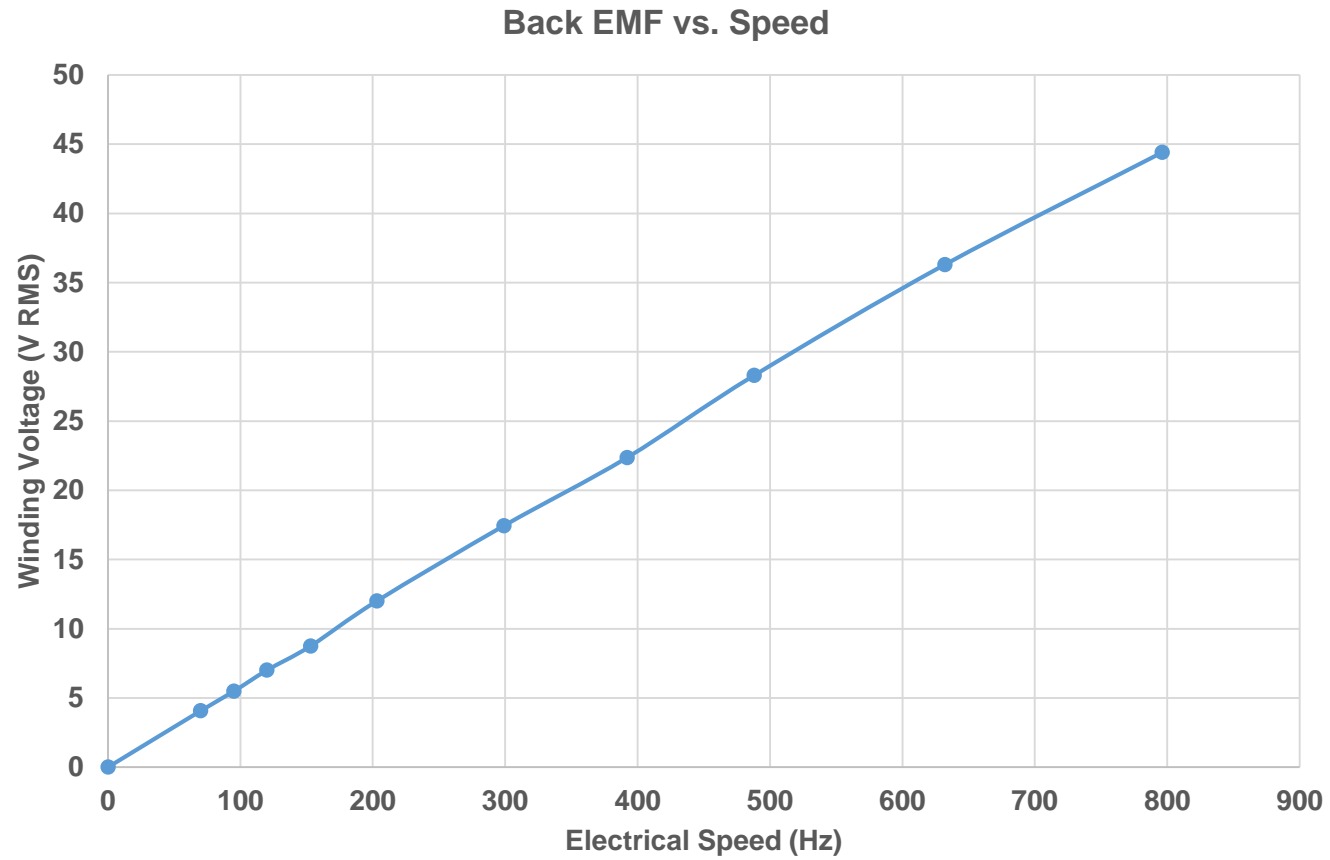

# Measuring the Back EMF

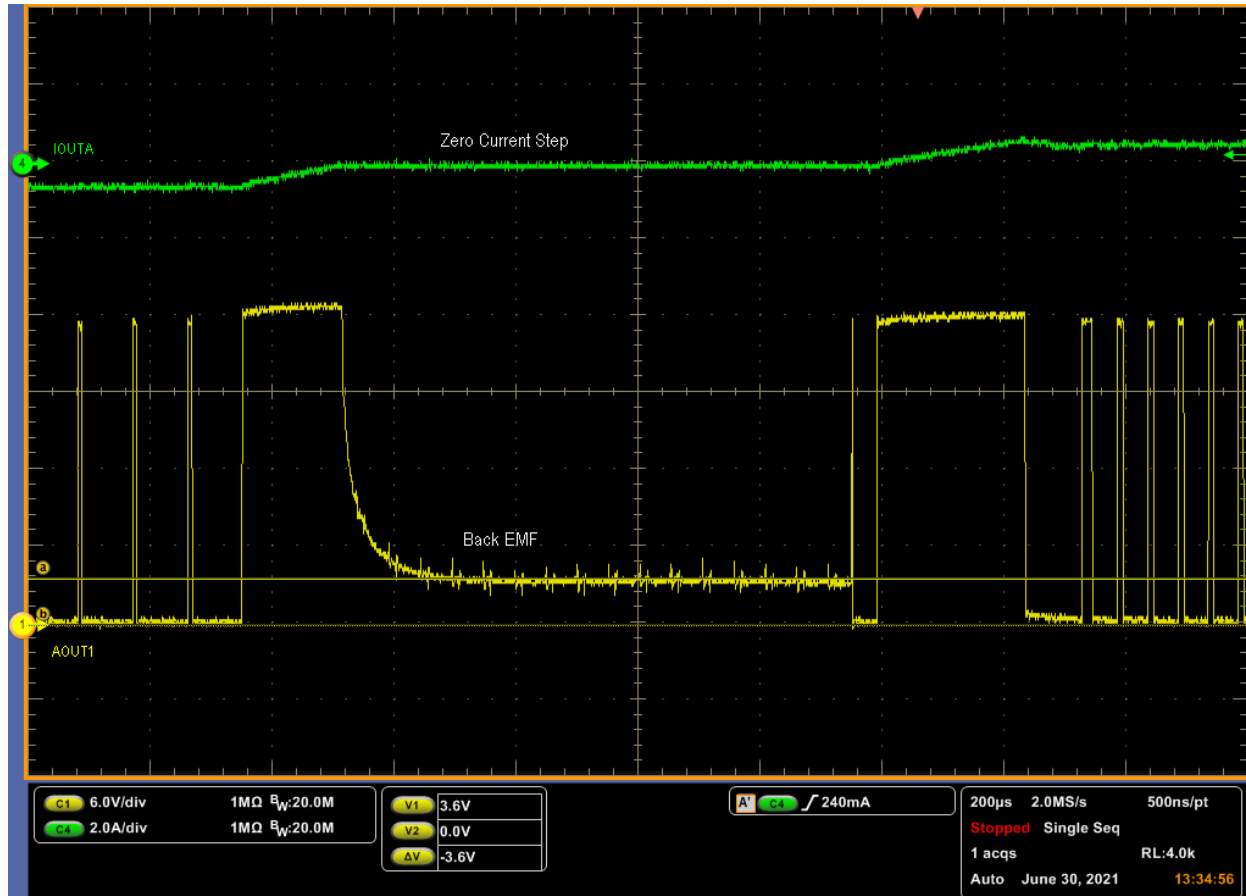

# Back EMF Measurements vs. Rotor Speed

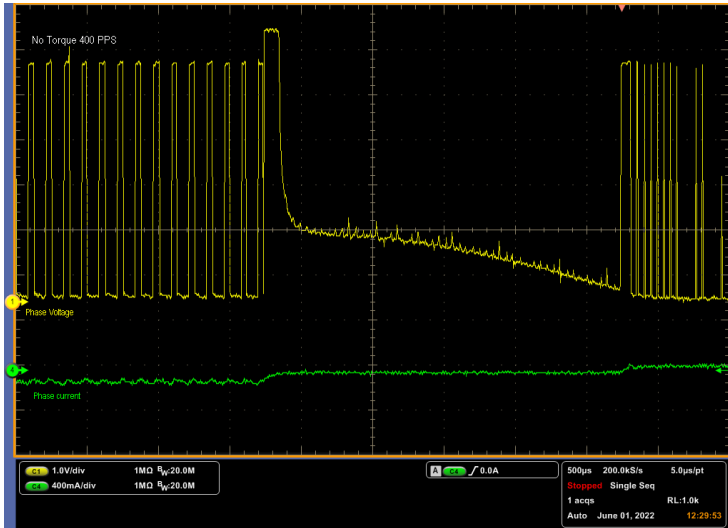

400 PPS

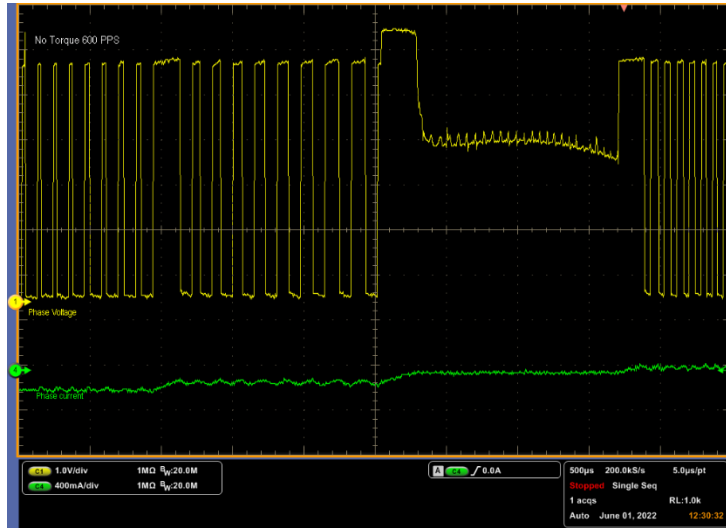

600 PPS

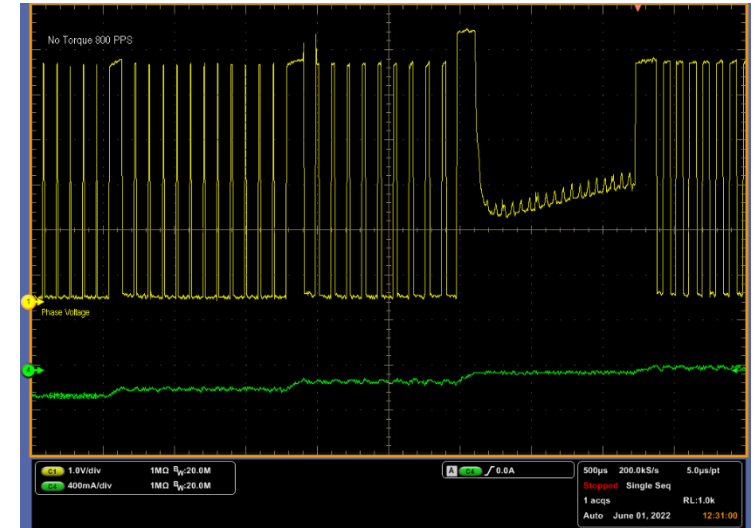

800 PPS

# How to Measure BEMF?

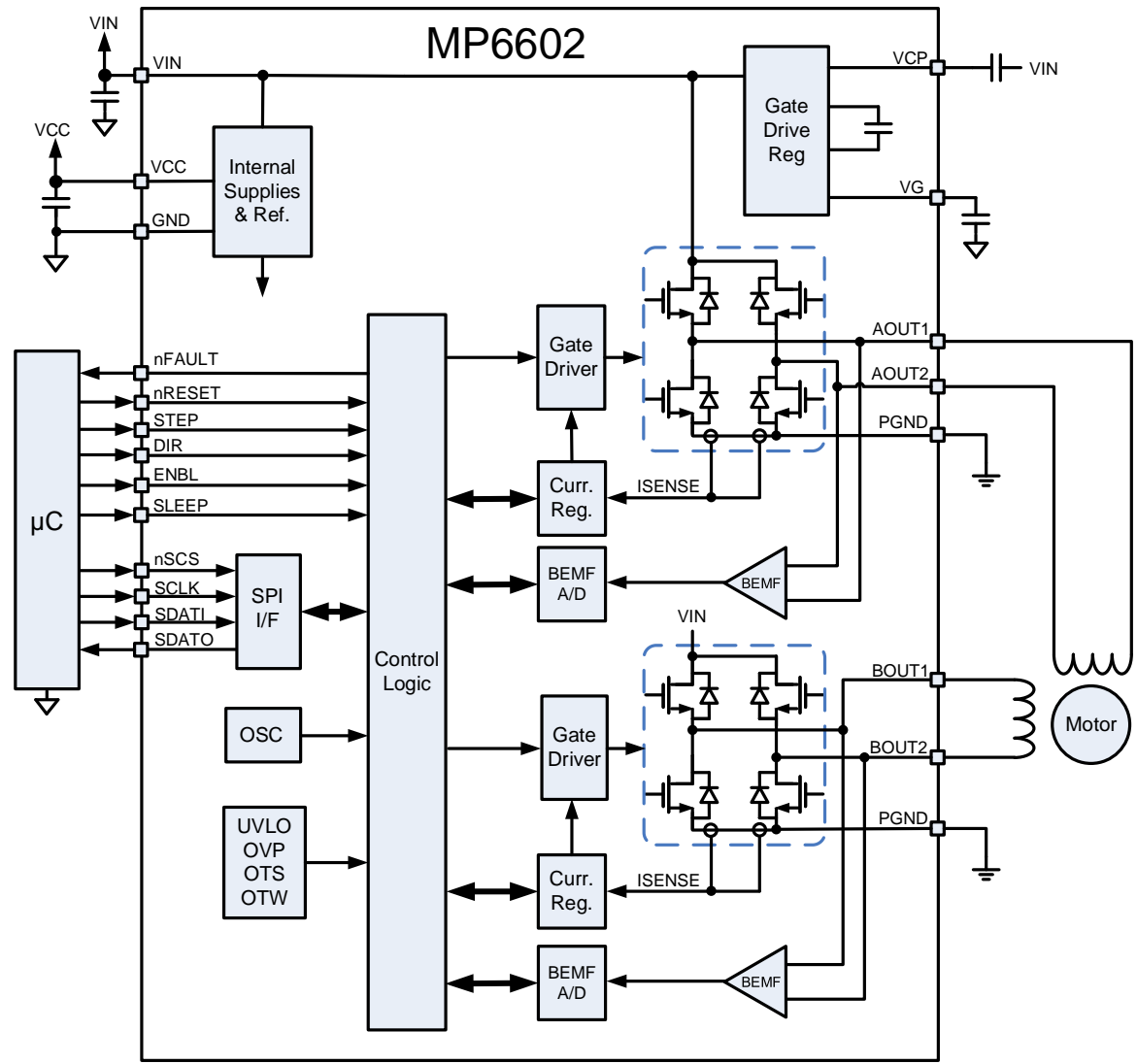

# Stall Detection

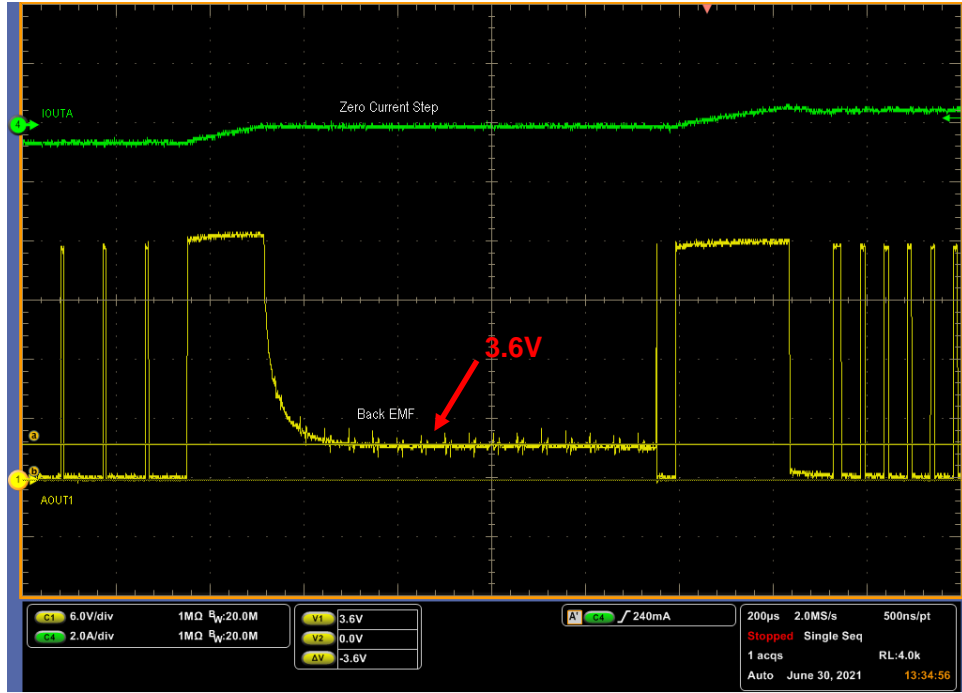

**Rotating**  
**Back EMF = 3.6V**

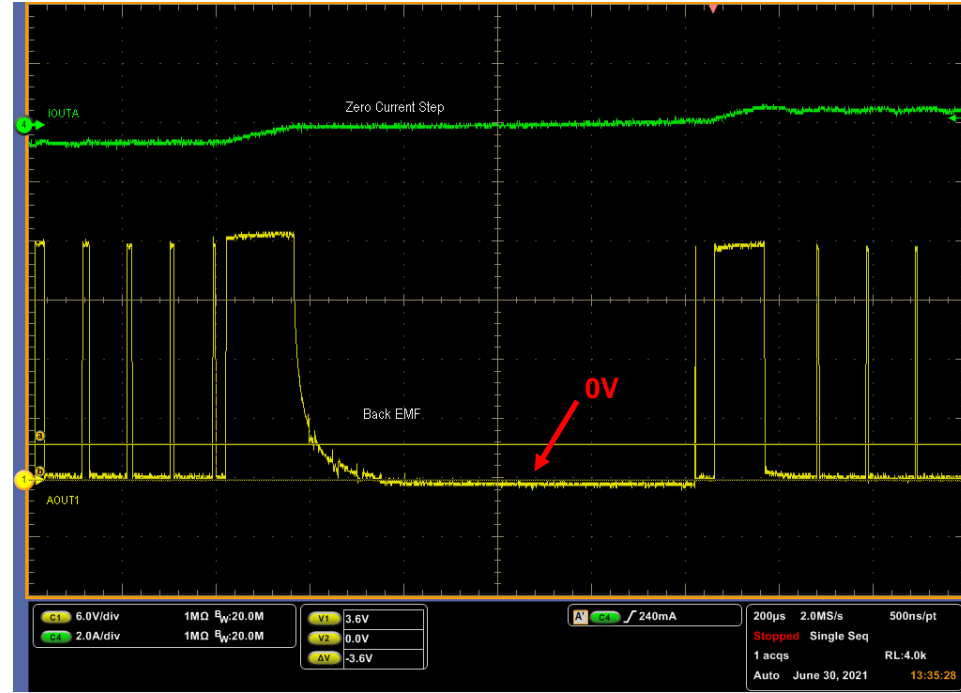

**Stalled**  
**Back EMF = 0**

# MP6602 Stall Detection

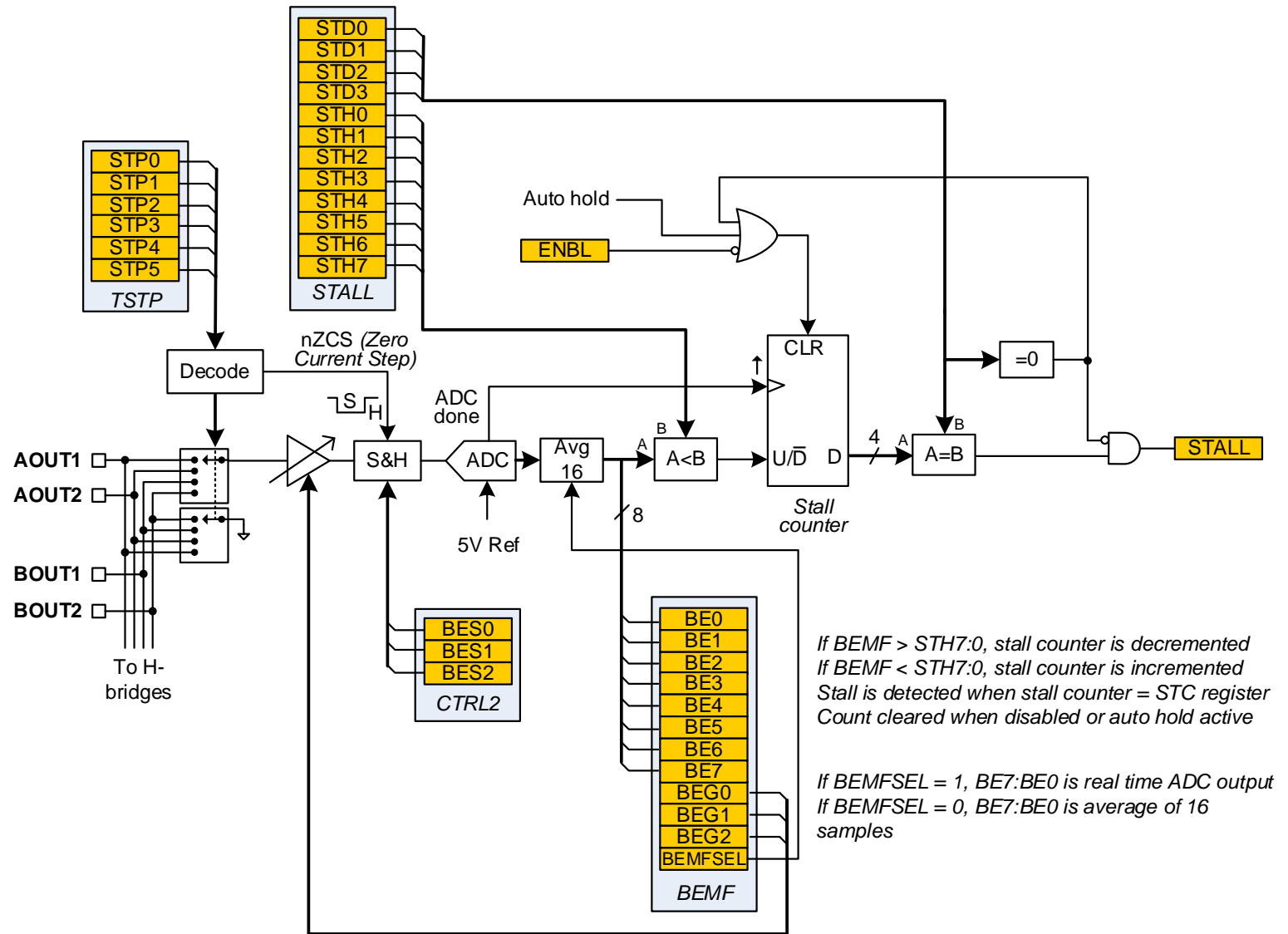



# Low Step Rates

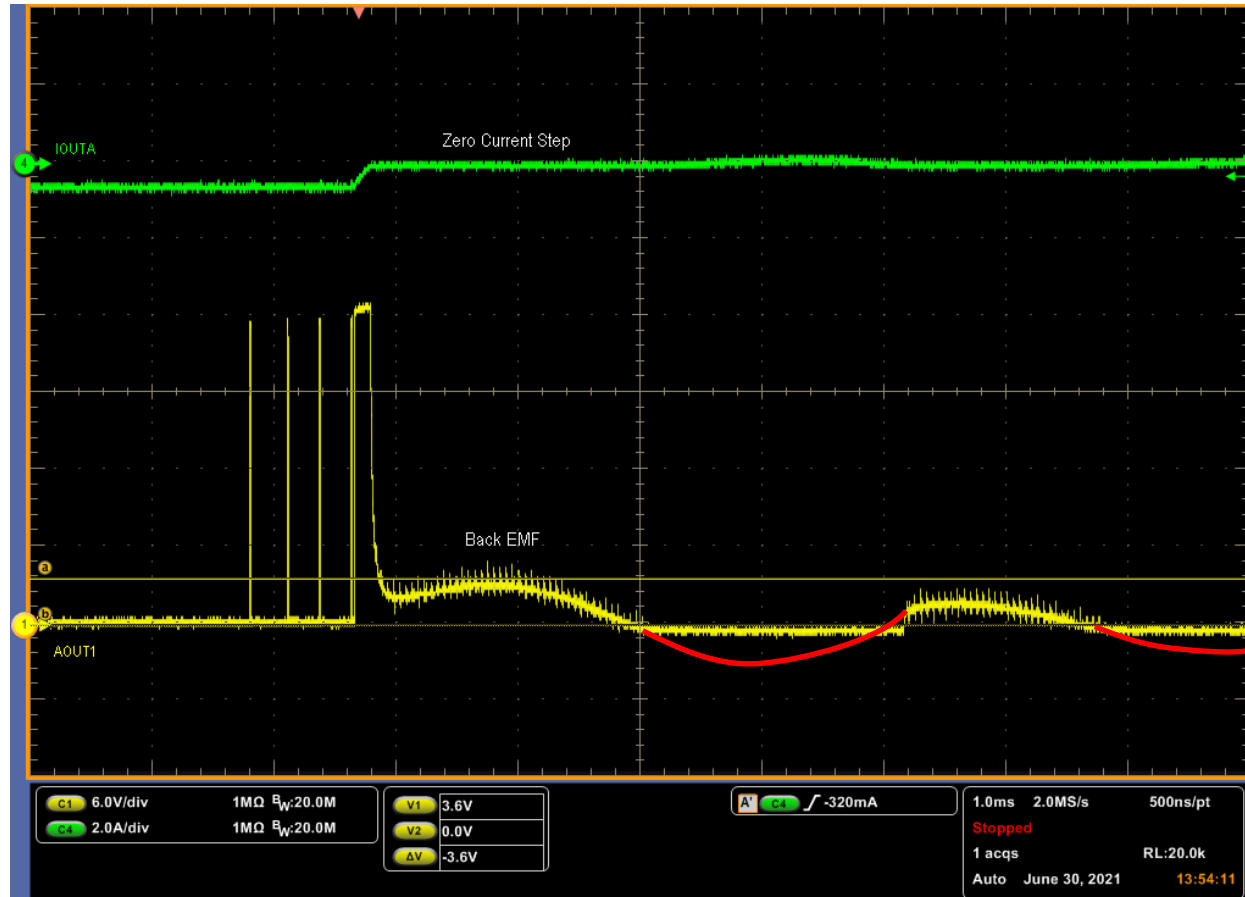

# Load Torque Estimation



Unloaded

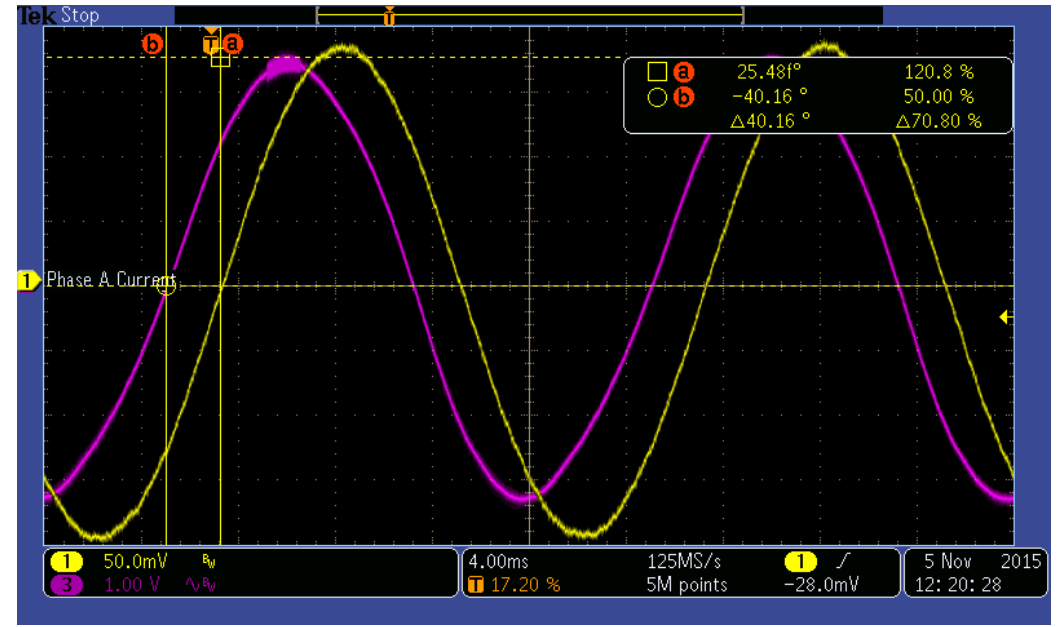

Loaded

Magenta: Voltage Yellow: Current

# Load Torque Estimation via BEMF Measurement

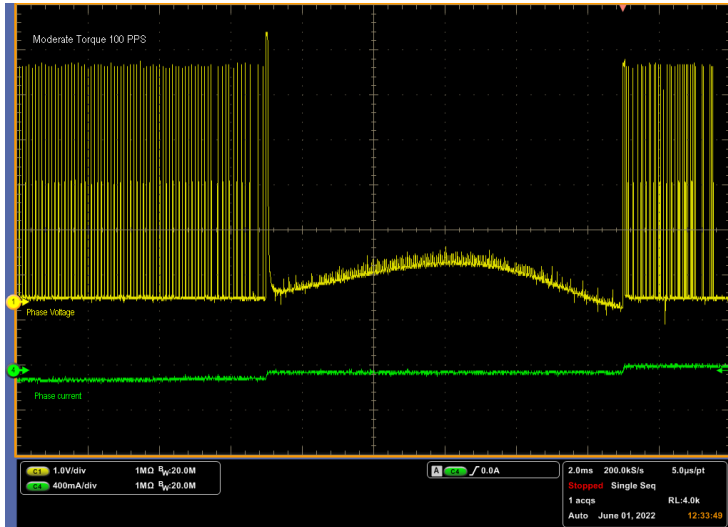

No Torque

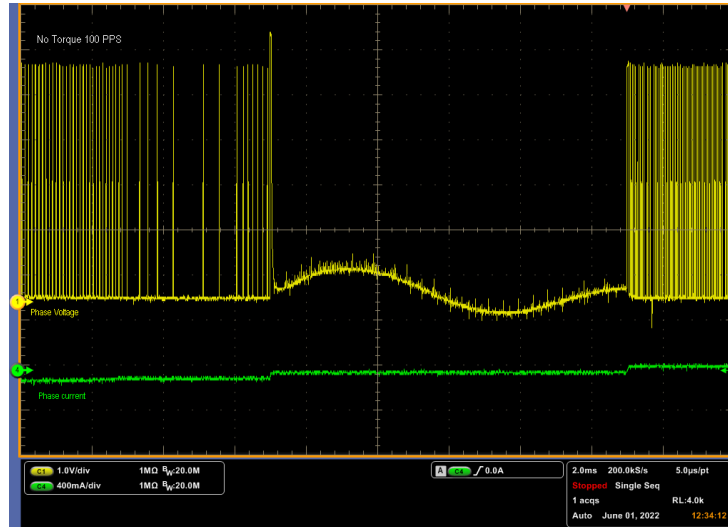

Moderate Torque

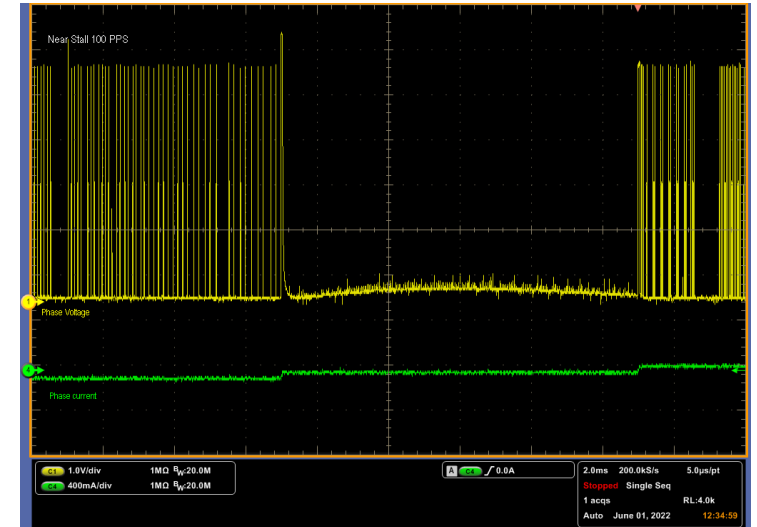

Near Stall

# Load Torque vs. BEMF

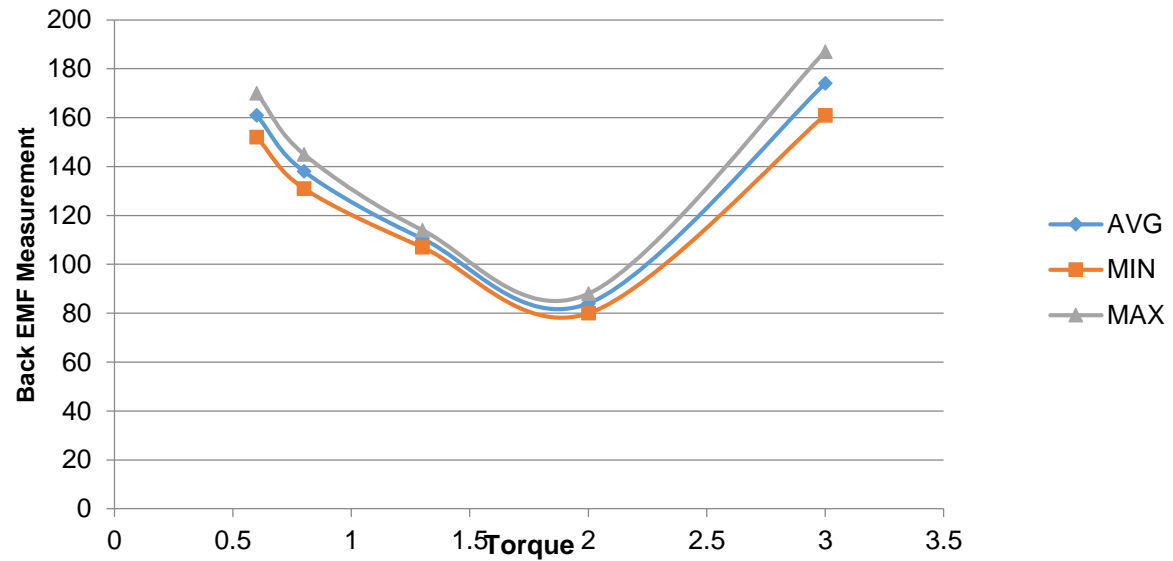
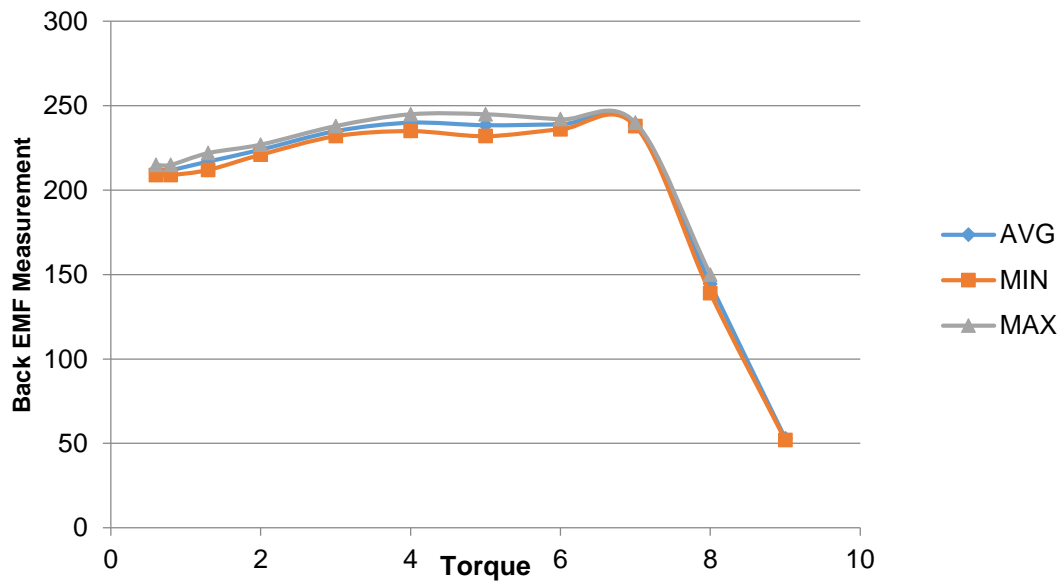

# Summary

- Stepper motors have back EMF, like any permanent magnet motor
- Back EMF effects the winding current, and the ability to step the motor at high speed
- Back EMF measurement can be used to provide stall detection, and in some cases provide diagnostic information

Please submit questions through the “Q&A” menu option in the Zoom app

This webinar and others will be available for on-demand streaming at:

[MonolithicPower.com/webinars](https://MonolithicPower.com/webinars)